



TV1106

Ku-Band 1.5 Watt BUC

TV1106

Ku-Band 1.5W BUC



- Low Cost Constant Gain VSAT BUC
- Low Local Oscillator Phase Noise
- Dual Loop PLL-Type Local Oscillator with External 10 MHz Reference
- Output Receive Reject Filtering
- Rugged Housing with High Thermal Margin, Compact Size
- O-ring, Hardware Included
- EN 301 428 & FCC 47 CFR 15/25 Compliant up to 2.4m Antenna
- CE Compliant
- RoHS Compliant



Dimensions

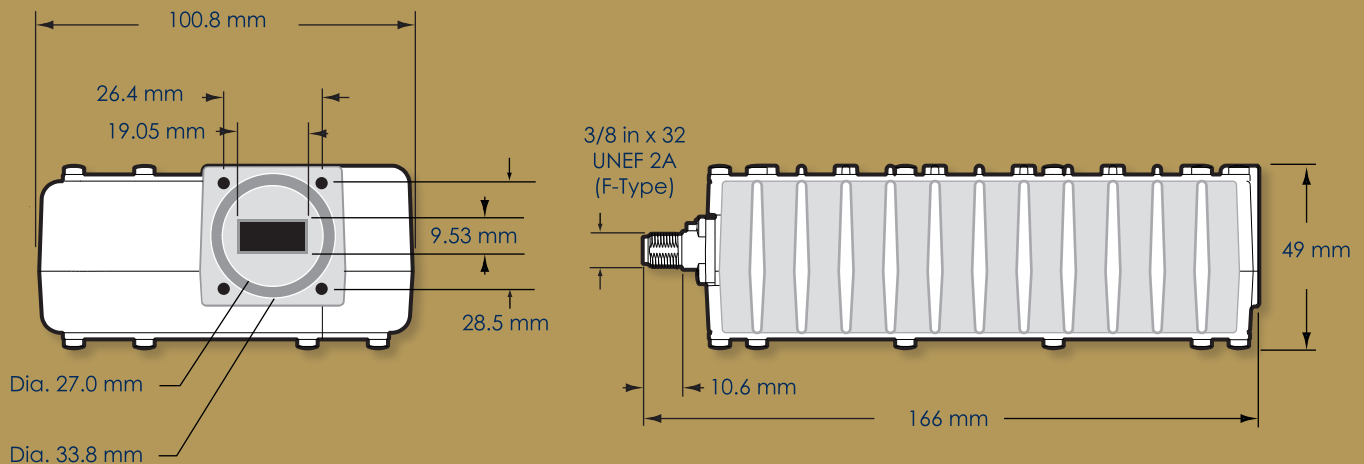

SPECIFICATIONS

TV1106

Ku-Band 1.5 Watt BUC

Block Up Converter with External Reference

Parameter	Minimum	Typical	Maximum	Unit	Note
IF Input Frequency Range	950		1450	MHz	
RF Output Frequency Range	14.00		14.50	GHz	
Local Oscillator Frequency (Nominal)		13.05		GHz	nominal
Local Oscillator Integrated Phase Noise, 100 Hz - 1 MHz		1.2	2.0	°K	DSB rms phase jitter
Local Oscillator Reference Frequency		10		MHz	sine wave
RF Output Power	P1dB	31.0	32.0	dBm	over frequency, operational conditions, and lifetime
	Psat	32.0	33.0	dBm	
RF Output ACPR @ Po = 30.5 dBm				26	dBc
RF Output Spurious Level					Compliant with EN 301 428 as well as FCC 47 CFR Part 15/25 with 29-25 log θ antennas up to 2.4m aperture
RF Output Noise Density	8.30-10.35 GHz		-117	dBm/Hz	
	10.95-12.75 GHz		-162	dBm/Hz	
	13.75-14.75 GHz		-94	dBm/Hz	
Conversion Gain	49	52	55	dB	over frequency, operational conditions, and lifetime
IF Input Impedance		75		Ohm	
IF Input Return Loss	10			dB	
Supply Voltage	13		28	V	
Supply Power Consumption	carrier off		11	W	
	at Psat		16	W	
IF Input Connector					F-type female
RF Output Connector					WR75 flange, grooved (O-ring included)

General Specifications

Parameter	Minimum	Typical	Maximum	Unit	Note
Weight		900		g	
Operating Temperature	-40		55	°C	
Moisture/Humidity Protection					IP67



Skyware Technologies

Kreuzweg 60, 47809 Krefeld, Germany
+49 2151 5350 258 • info@skywaretechnologies.com
www.skywaretechnologies.com

All designs, specifications and availabilities of products and services presented in this bulletin are typical and subject to change without notice.

SKTSE-004.2
© 2014 Skyware Technologies